

# SCREEN MACHINE INDUSTRIES, INC.

SCALPER 77C — *(Matches to 1 – 2 CuYd. Loaders)*  
New Product Introduction – ConExpo 2008

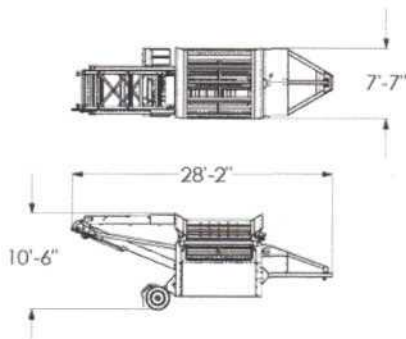

Visit Us  
Booth C-6523

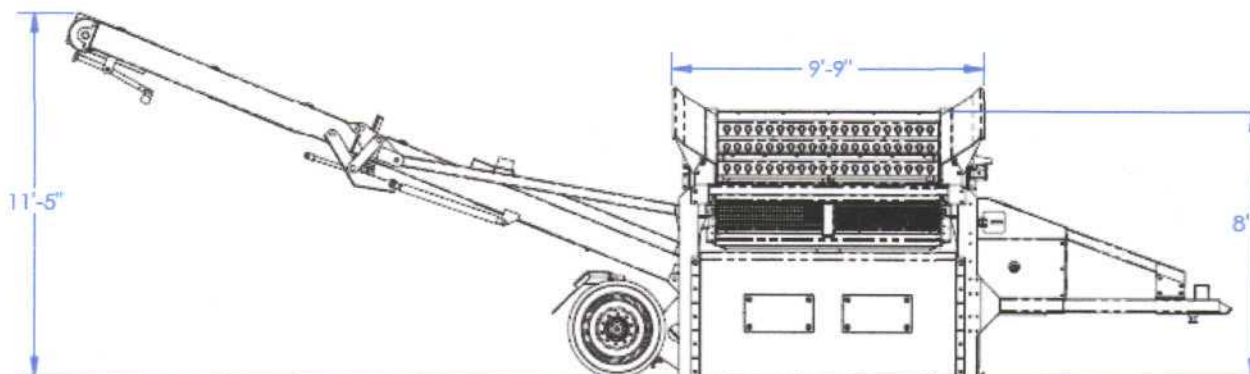

Equipment Specialist  
Buy • Sell • Lease

## MURRYSVILLE MACHINERY COMPANY

1000 COMMERCIAL COURT  
IRWIN, PA 15642

PHONE: (724) 863-7000

FAX: (724) 863-9908

[www.murrysvillemachinery.com](http://www.murrysvillemachinery.com)

# THE SCREEN MACHINE SCALPER 77C

Page 1 of 2 (pg. 2 = screens to follow soon)

PORTABLE SCREENING PLANT

## KEY FEATURES

48 H.P. Yanmar Diesel Engine

8' - 3" (2.51M) Low Feed Height

9' - 9" (2.97M) Feed Width Across Deck Span

11' - 5" (3.48M) Conveyor Discharge Height for Fines Material

Grade 80 Steel Construction for Optimum Life Cycle Value

Smooth Start Technology (US Patent Award # 6,401,993)

Locked Control Panels and Murphy Shut Offs

Made in the USA (Columbus, OH)

---

## **Base Unit Standard Specifications:**

### Screen

Grade 80 Steel / Two Bearing Screen Design

7'-0" X 7'-0" Top screen deck (1 screen)

7'-0" X 6'-0" Bottom deck (2 screens)

Smooth Start Technology (US Patent Award # 6,401,993)

Extensive variety of screen types to meet all applications

Hydraulic Quick disconnect lines for reverse deck throw

10" (25.4 cm) Clearance between decks

9' - 9" (2.97 M) Feed width across deck span

8' - 3" (2.51) Feed load over height

### Structure

Grade 80 steel construction

Single axle with dual 255 / 70 x R22.5 - low profile tires

Hydraulic axle raise and lower

Hydraulic landing gear for ease of tow hook up

5" (12.7 cm) Troughing can idlers

5" (12.7 cm) Rubber disc returns & gravity belt scraper

Hydraulic folding - finished material stockpile conveyor

36" Main Discharge Belt with guide rollers

Wing type wrapped tail pulley for excellent ground clearance

Lagged type - Herringbone Head Pulley

Remote grease lines for all bearings for ease of access

### Power System

48 H.P. Yanmar Diesel Engine

Liquid Cooled - Naturally Aspirated Tier II Engine

42 gallon (baffled & lockable) hydraulic tank & oil cooler  
w/ Hydraulic Temperature Shut Down Sensor

40 Gallon diesel fuel tank

Locked control panels & Murphy shut offs

### Shipping Information

Height 10' - 6" (3.2 M)

Length 28' - 2" (8.59 M)

Width 7' - 7" (2.31 M)

Weight (approx.) 19,500 lbs. (8,846 KG)

Air Brakes with Brake Lights

Fenders

Directional Lights

Mud Flaps

Standard: Fifth Wheel Tow Configuration

Optional: Pintle Hook Tow Arrangement (bolt on configuration)

### Loader Operation

1 - 2 cubic yard loader (.76 Cu. M - 1.53 Cu. M)



Equipment Specialist  
Buy • Sell • Lease

## MURRYSVILLE MACHINERY COMPANY

1000 COMMERCIAL COURT  
IRWIN, PA 15642

PHONE: (724) 863-7000

FAX: (724) 863-9908

www.murrysvillemachinery.com