

THE SCREEN MACHINE®

ECONOMICAL & VERSATILE
PORTABLE STACKING CONVEYORS

MODEL TH-80SF
MODEL TE-80SF



MORE STOCKPILING CAPACITY

THE SCREEN MACHINE Portable Truss Conveyors have a special heavy duty design including a side fold for highway travel and angling for greater discharge height providing larger piles.



TOTAL ESTIMATED CAPACITY OF PILES INCLUDING ENDS

CONVEYOR LENGTH	HEIGHT OF PILE	BASE DIA. OF PILE	CONICAL PILE	INCLUDED ANGLE OF PILE					TONS	CU. YDS.	
				30°	45°	60°	90°	120°			180°
STD 80'	27'-6"	73'	1918	3943	4956	5968	7993	10018	14068		
			1421	2921	3671	4421	5921	7421	10421		
OCS 80'	32'	83'-6"	2955	5468	6723	7979	10492	13004	18029		
			2189	4051	4980	5911	7772	9633	13355		

BASED ON 100% CU. FT. MATERIAL. TABLE IS A GUIDE ONLY.



Equipment Specialist

MURRYSVILLE MACHINERY COMPANY

1000 COMMERCIAL COURT
IRWIN, PA 15642
PHONE: (724) 863-7000

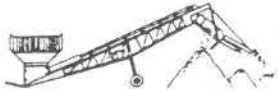

Equipment Specialist
Buy • Sell • Lease

MURRYSVILLE MACHINERY COMPANY

1000 COMMERCIAL COURT
IRWIN, PA 15642
PHONE: (724) 863-7000

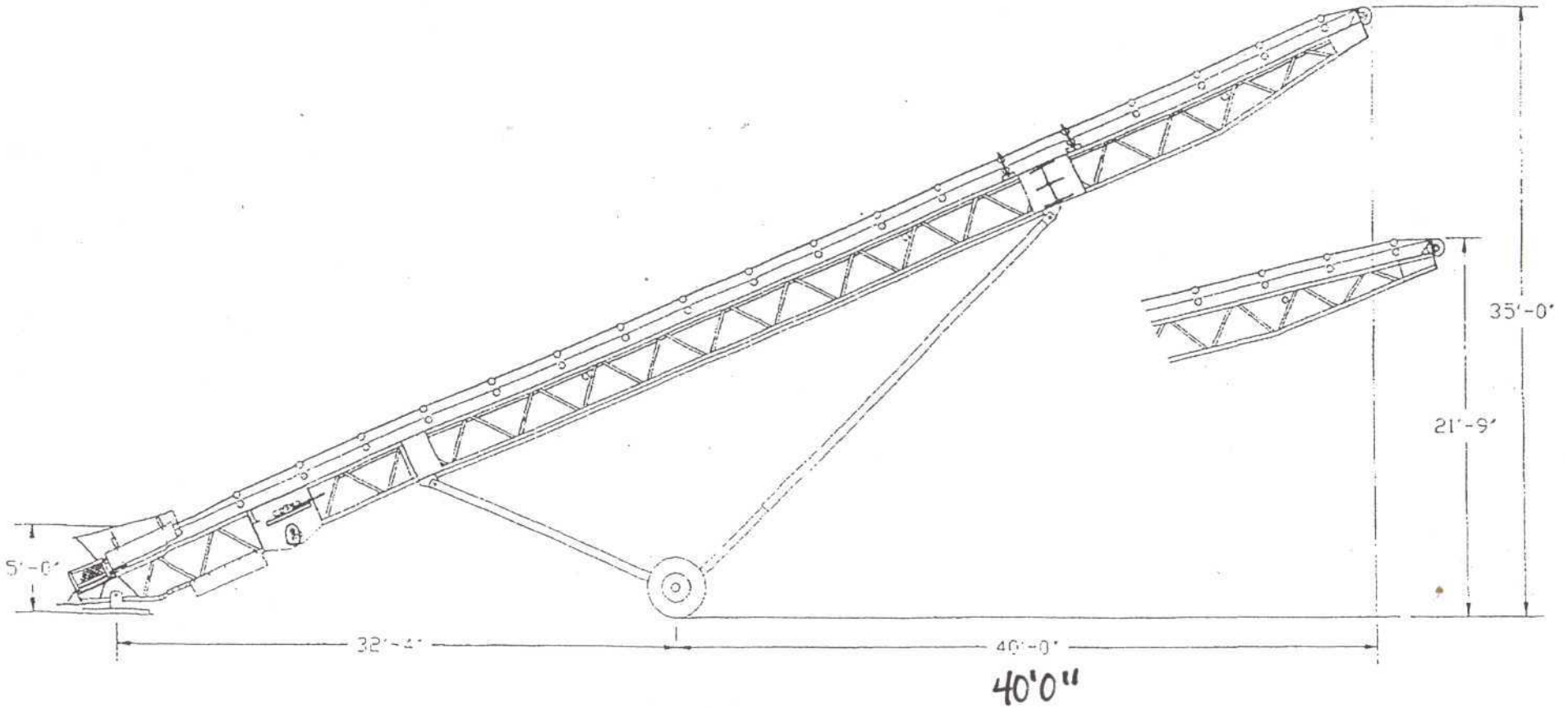

The Screen Machine

30" x 80' Radial Stacking Conveyor

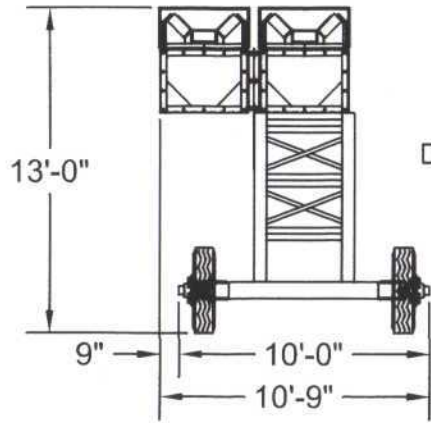

Section A-A: Single Wheel
Approximate Weight: 17,600 lbs

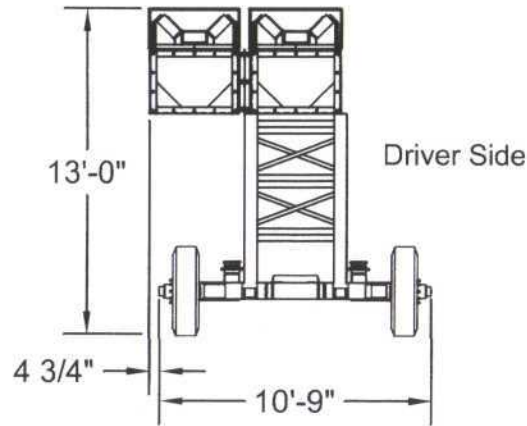

Section A-A: Super Single Wheel - Air Brake
Approximate Weight: 17,950 lbs
Approximate Weight w/ Diesel Module: 20,050 lbs

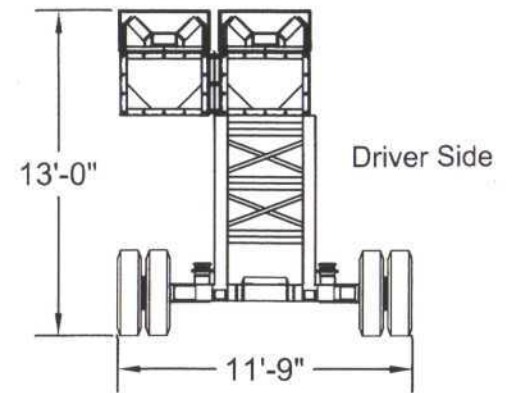

Section A-A: Dual Wheel - Air Brake
Approximate Weight: 18,100 lbs
Approximate Weight w/ Diesel Module: 20,200 lbs

